

# G3系列 / G3 Series

## 超小型防水防尘微动开关

Subminiature Sealed Micro Switch



### ■ 特点/Features

- ◆ 防水防尘 (IP67) 设计
- ◆ 体形小巧, 紧凑
- ◆ 拥有全球安规认证
- ◆ 长寿命, 高可靠性
- ◆ 配备各种形式的操作柄
- ◆ 接线端子种类齐全
- ◆ 广泛应用于汽车控制、家电控制、工业控制等领域
- ◆ 多种安装外形尺寸满足不同的安装要求

- Designed For Water and Dust Tight(IP67)
- Small Compact Size
- Global Safety Approvals
- Long Life and High Reliability
- Variety of Levers
- Wide Range of Wiring Terminals
- Widely used in Automotive Electronics,Appliance and Industrial Control etc.
- Customized Designs

### ■ 应用/Application

- ◆ 汽车/Car
- ◆ 空调/Air-Conditioner
- ◆ 通信/Communication
- ◆ 电动牙刷/Electric Tooth Brush
- ◆ 玩具/Toys
- ◆ 家用电器/Home Appliance
- ◆ 电机控制器/Motor Control

### ■ 特性参数/Parameters:

额定值/Rating		0.1A,125/250VAC;3A/12VDC;0.1A/48VDC; $\mu$ 1E5.
操作频率 Operating Frequency	电气/Electrical	0.1A-120次/分; 3A-10~30次/分 cycles/minute
	机械/Mechanical	120次/分cycles/minute
初始接触电阻/Contact Resistance(Initiative)		100m $\Omega$ Max(不带线型/without wire type)
绝缘电阻/Insulation Resistance(at500VDC)		100M $\Omega$ Min
抗振动/Vibration durability		10~55Hz,位移/move0.75mm(p-p)
抗电强度/Dielectric Strength		500VAC(50~60Hz)
保存温度/Storage Temperature		-40 $^{\circ}$ C ~ +85 $^{\circ}$ C
保存湿度/Storage Humidity		85%RHMax
寿命/Service Life	电气/Electrical	Min.100,000次/cycles(取决于具体型号/Depend on part No.)
	机械/Mechanical	Min.500,000次/cycles

## G3 系列微动开关订货型号指引 G3 Series Micro Switch Ordering Instruction

G3	03	130	S		00	A
Switch Type 开关类别	Electrical Rating 额定负载	Operating Force at pin Plunger,Max 操作力(最大值) 数据在不带操作柄测得	Terminal Style 端子类型		Lever Type 操作柄类型	Circuit Code 接触形式
G3 Series Micro Switch G3 系列微动开关	03 ENEC:0.1A 125/250VAC 48VDC:3A 12VDC u 1E5 UL: 0.1A 125/250VAC 48VDC:3A 12VDC	130 130gf Max. (使用 130#弹簧)	E Molded lead wires downwards. 带电线型号 底面出线	Q 2.5 type terminals 2.5型端子 (端子宽 2.5mm, 长度 7.5mm)	00 No lever 不带操作柄 Pin Plunger 柱式按捺	A SPDT 单极双投
		075 75gf Max.(使用75# 弹簧)	G Molded lead wires on left side(plunger side) 带电线型号 左侧(按捺侧)出线	Q1 2.5 type 1# terminals 2.5型1#端子 (端子宽 2.5mm, 长度6.7mm)	01 Leaf lever 水平手柄 (用于A型、A1型、M3型)	B SPST - NC 单极单投-常闭
	...	Other 其他	F Molded lead wires on right side(plunger side) 带电线型号 右侧(远离按捺侧)出线	D 2.5 type 2# terminals 2.5型2#端子 (端子宽 2.5mm, 长度5.15mm)	02 Straight Leaf lever 直手柄 (用于A型、A1型、M3型)	C SPST - NO 单极单投-常开
			S Solder terminals 焊接端子	Q3 2.5 type 3# terminals 2.5型3#端子 (端子宽 2.5mm, 长度8.2mm)	03 03# straight lever(Only for C type case) 03#直手柄 (专用于C型胶壳)	
			M Short Solder terminals 短焊接端子	X Wide bottom PCB Terminals 宽底PCB 端子 (0.9mm宽 /wide)	05 Simulated Roller 模拟滚轮手柄 (用于A型、A1型、M3型)	
			K Long solder terminals 长焊接端子	Y Wide bottom PCB Terminals 自锁型宽底PCB 端子 (0.9mm宽/wide)	09 Mini Simulated Roller lever 小模拟滚轮手柄 (用于A型、A1型、M3型)	
			N None-hole short Solder terminals 无孔短焊接端子	A Left Side Fork type terminals 叉型左向端子	10 10# lever 10# 手柄(用于A型、A1型带PHA防水壳)	
			P Straight PCB terminals (0.6mm width) 直PCB 端子 (0.6mm宽, 长 3.5mm, 底座有凸台)	B Right Side Fork type terminals 叉型右向端子	13 13# lever(Only for T type case) 13# 手柄 (专用于T型)	
			P1 Straight PCB terminals (0.6mm width) 直PCB 端子 (0.6mm宽, 长 2.5mm, 底座有凸台)		15 Upside down simulated roller lever 倒圆弧手柄 (用于A型、A1型、M3型)	
			R Right side PCB terminals 右侧PCB 端子		22 22# lever 22# 手柄 (用于A型、A1型、M3型)	
		L Left side PCB terminals 左侧PCB 端子		23 23# lever 23# 手柄, (专用于C1M3胶壳)		
		I Big Solder terminals 大焊接端子 (端子孔径 1.8mm)		25 25# lever 25# 手柄 (用于A型、A1型、M3型)		
		J Left Right straight PCB terminals 左右直PCB 端子		28 28# lever 28# 手柄 (用于A型、A1型、M3型)		
				35 35# lever 35# 手柄 (用于A型、A1型、M3型)		
				36 36# lever 36# 手柄(用于A型、A1型、M3型)		
				41 41# lever 41# 手柄(用于A型、A1型、M3型)		
				... Other 其他		

2			A			E	A	280	Special Designator
Shape and Posts 外形与定位柱			Posts Dimension 定位柱尺寸			AWG Type(for Wire type only) 线号 (仅适用于带线型)	AWG Number(For Wire type only) 线号 (仅适用于带线型)	Wires length 线长	Special Designator 特别设计代码
1	A type no post A型无定位柱	20	C2 type two sides posts C2 型双侧定位柱	47	C1M3 type posts C1M3型定位柱		No molded lead wires 不带电线	300mm length standard lead wires 300mm 标准线长	S Special code 特殊说明
2	A type left side posts A型左定位柱	21	C2 type no post C2 型无定位柱	48	A2 type posts A2型无定位柱 (用于带线开关)	A	18# 只适用于底面出线开关 Only applicable to bottom outlet switch	280 280mm length 280mm长	.....
3	A type right side posts A型右定位柱	22	C2 type left posts C2 型左定位柱	49	A2 type posts A2型左定位柱 (用于带线开关)	B	20# 只适用于A型、A1型、M3型底面出线开关、C型出二线开关 Only applicable to A type, A1 type, M3 type bottom outlet switch, C type out of two line wire switch	... Other 其他	
4	B type no post B型无定位柱	23	C2 type right posts C2 型右定位柱	50	A2 type posts A2型右定位柱 (用于带线开关)	C	F 22#	D UL1061	
5	B type left posts B型左定位柱	24	D2 type no post D2 型无定位柱	51	A2 type posts A2型双定位柱 (用于带线开关)	D	G 24#	E UL1330	
6	B type right side posts B型右定位柱	25	D2 type left side posts D2 型左定位柱	52	A2 type posts A2型无定位柱 (用于不带线开关)	E	H 26#	F AVSS	
7	M3 type posts M3型定位柱	26	D2 type right side posts D2 型右定位柱	53	A2 type posts A2型左定位柱 (用于不带线开关)	F	I 28#	H UL1332	
8	A type two sides posts A型双侧定位柱	27	D2 type two sides posts D2 型双侧定位柱	54	A2 type posts A2型右定位柱 (用于不带线开关)	H	J 30#	L FLRY-A	
9	B type two sides posts B型双侧定位柱	28	A type no post A型方孔无柱	55	A2 type posts A2型双定位柱 (用于不带线开关)	K	K 32#	I UL1332 (硅胶线)	
12	C1 type two sides posts C1型双侧定位柱	29	A type left side posts A型方孔左定位柱	...	Other 其他	...	L 34#	... Other 其他	
13	C1 type no post C1 型无定位柱	30	A type right side posts A型方孔右定位柱	...	Other 其他	...	... Other 其他		
14	C1 type left posts C1 型左定位柱	31	A type two sides posts A型方孔双侧定位柱						
15	C1 type right posts C1 型右定位柱	32	T type no post T型无定位柱						
16	D1 type no post D1 型无定位柱	33	T type left side posts T型左定位柱						
17	D1 type left side posts D1 型左定位柱	34	T type right side posts T型右定位柱						
18	D1 type right side posts D1 型右定位柱								
19	D1 type two sides posts D1 型双侧定位柱								

**G3系列 | 安装孔位、操作柄类型、接触形式、外形介绍、端子类**  
**G3 Series | Mounting Hole, Lever Type, Circuit, Shape, Terminal Type**

**■ 安装孔尺寸/Mounting Hole Dimensions**

<p>Posts with different dia. 2-直径不同的定位柱</p> <p>定位柱间距 Dimension between Posts</p>	<p>按掣位置</p> <p>直PCB端子安装孔 Straight PCB terminals mounting hole</p>	<p>定位柱方向识别 Posts Identification</p>
<p>左右PCB端子安装孔 Left/Right Angled PCB terminals mounting hole</p>	<p>M3 型安装孔 M3 type mounting hole</p>	<p>按掣位置 Plunger Position</p> <p>Left 左向 Right 右向</p>
<p>Mounting Hole Dimensions</p> <p>2-Φ3.00</p> <p>12.00</p> <p>T 型3.0安装孔 T type 3.0 mounting hole</p>	<p>Mounting Hole Dimensions</p> <p>2-Φ4.00</p> <p>12.00</p> <p>T 型4.0安装孔 T type 4.0 mounting hole</p>	

**■ 操作柄类型/Lever Type**

<p>00#: 柱式按掣/Pin Plunger</p>	<p>01#: 水平手柄/Leaf Lever</p>	<p>02#: 直手柄/Straight Leaf Lever</p>
<p>03#: 直手柄/Straight Leaf Lever</p>	<p>05#: 模拟滚轮手柄/Simulated Roller Leaf Lever</p>	<p>09#: 小模拟滚轮手柄/Mini Simulated Roller Leaf Lever</p>



C 型基本外形 C type basic shape		D 型基本外形 D type basic shape	
 <p>NC NO COM</p> <p><b>C1型</b> C1 type</p>	 <p>COM NC NO</p> <p><b>C2型</b> C2 type</p>	 <p>NC NO COM</p> <p><b>D1型</b> D1 type</p>	 <p>COM NC NO</p> <p><b>D2型</b> D2 type</p>
C1M3型 C1M3shape		T型基本外形 T type basic shape	
			

## ■ 外形与定位柱/Shape and Posts

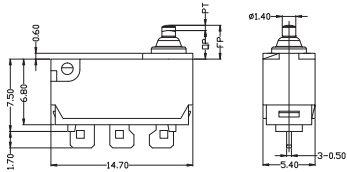
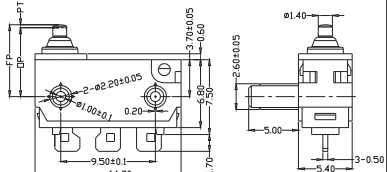
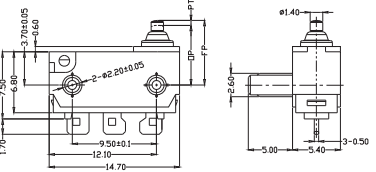
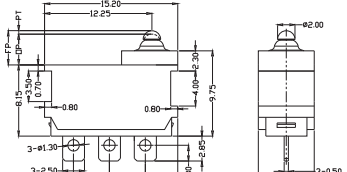
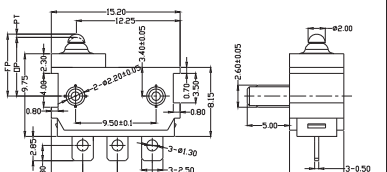
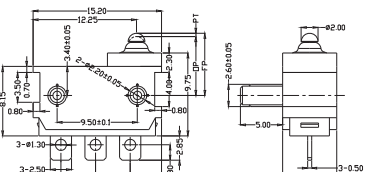
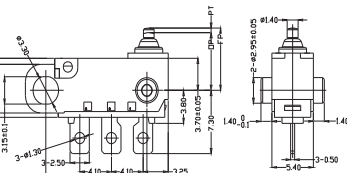
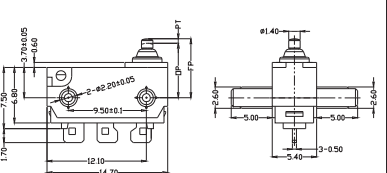
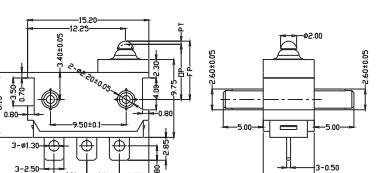
<p>1#: A型无定位柱/A type no post</p> 	<p>2#: A型左定位柱/A type left side posts</p> 	<p>3#: A型右定位柱/A type right side posts</p> 
<p>4#: B型无定位柱/B type no post</p> 	<p>5#: B type left side posts B型左定位柱</p> 	<p>6#: B型右定位柱/B type right side posts</p> 
<p>7#: M3型定位柱/M3 type posts</p> 	<p>8#: A型双侧定位柱/A type two side posts</p> 	<p>9#: B型双侧定位柱/B type two side posts</p> 

## ■ 外形与定位柱/Shape and Posts

<p>12#/20# : C1/C2型双侧定位柱 C1/C2 type two side posts</p>	<p>13#/21# : C1/C2型无定位柱 C1/C2 type no posts</p>	<p>14#/22# : C1/C2型左定位柱 C1/C2 type left side posts</p>
<p>15#/23# : C1/C2型右定位柱 C1/C2 type right side posts</p>	<p>16#/24# : D1/D2型无定位柱 D1/D2 type no post</p>	<p>17#/25# : D1/D2型左定位柱 D1/D2 type left side posts</p>
<p>18#/26# : D1/D2型右定位柱 D1/D2 type right side posts</p>	<p>19#/27# : D /D2型双侧定位柱 D1/D2 type two side posts</p>	<p>47# : C1M3型定位柱/C1M3 type posts</p>
<p>28# : A1型方孔无柱/A1 type no post</p>	<p>29# : A1型方孔左定位柱/A1 type left side</p>	<p>30# : A1型方孔右定位柱/ A1 type right side posts</p>
<p>31# : A1型方孔双侧定位柱/ A1 type two sides posts</p>		<p>33# : T type left side posts /T型左定位柱</p>
<p>34# :T type right side posts/T型右定位柱</p>		

## ■ 接触形式图/ Circuit Configuration

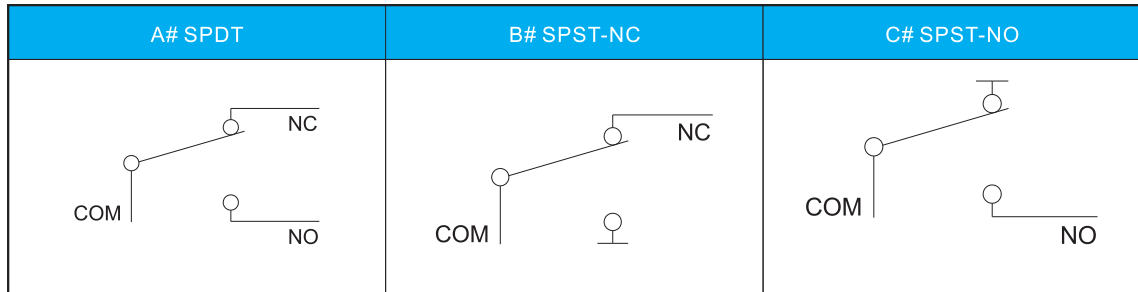

## ■ 定位柱尺寸/Posts Dimension

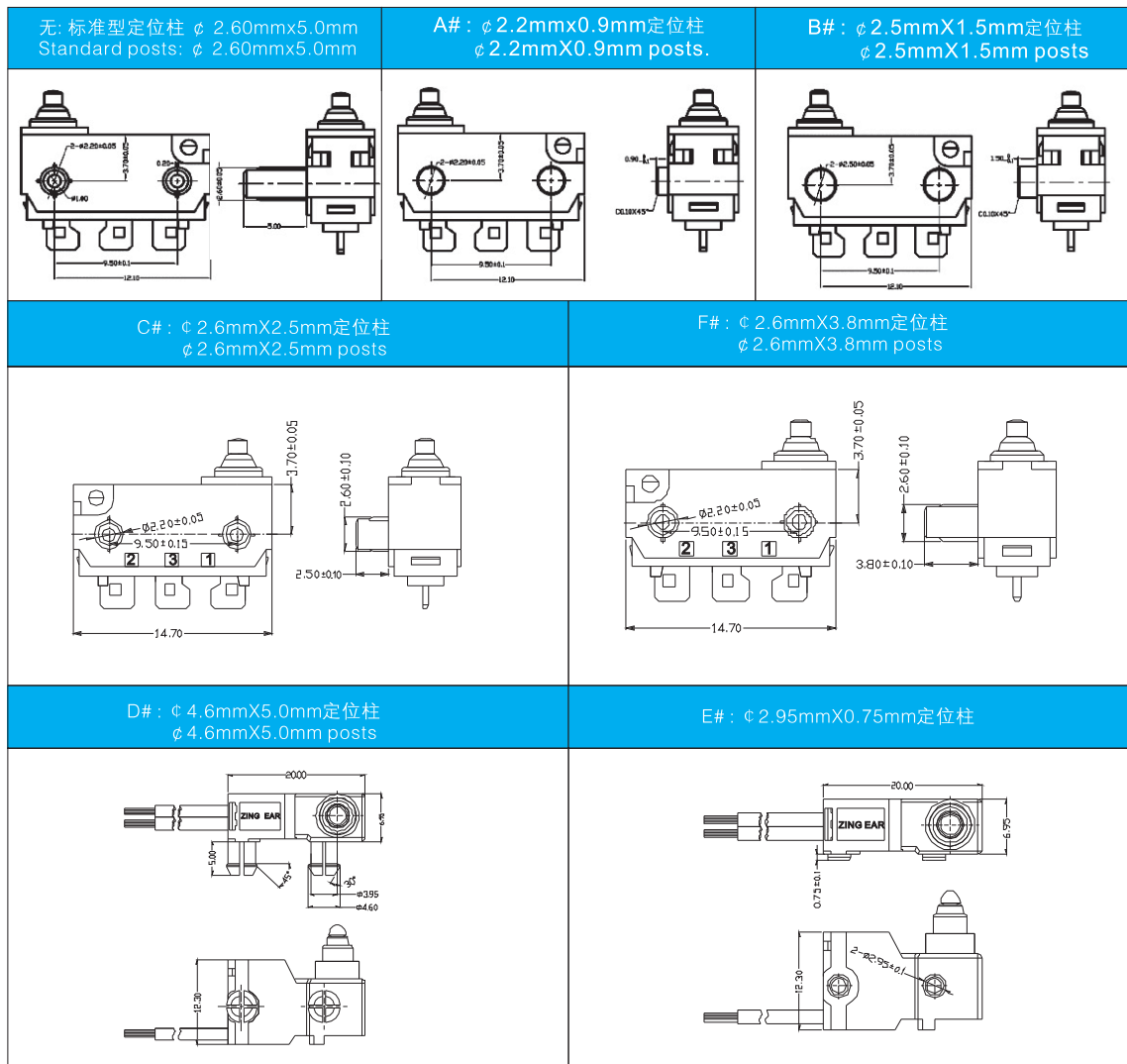



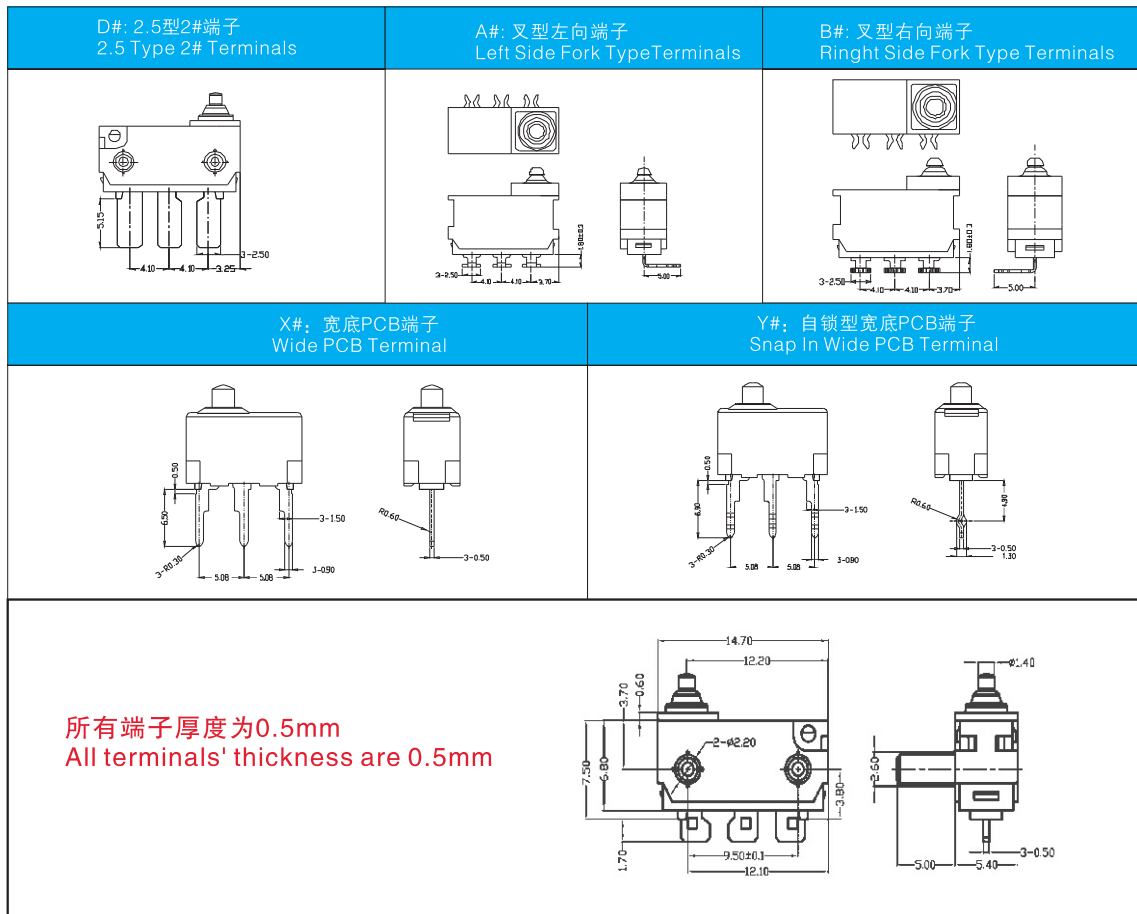

## ■ 外形尺寸和操作特性 Dimensions and Operating Characteristics

### ◆ G3□□-□□□S00A1

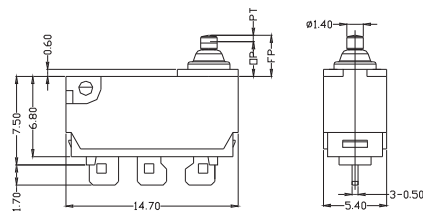

OF Max. (gf)	RF Min. (gf)	PT Max. (mm)	OT Min. (mm)	DT Max. (mm)	FP Max. (mm)	OP (mm)
-130	130	13	0.8	0.8	0.2	3.65
						3.05±0.2

### ◆ G3□□-□□□S01A1

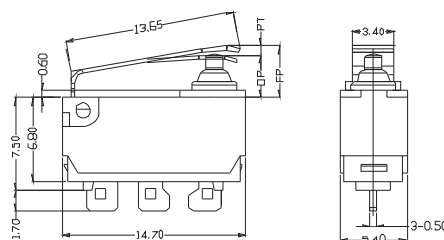

OF Max. (gf)	RF Min. (gf)	PT Max. (mm)	OT Min. (mm)	DT Max. (mm)	FP Max. (mm)	OP (mm)
-130	220	30	3	0.8	0.5	5.7
						3.4±0.5

## ◆ G3□□-□□□S02A1

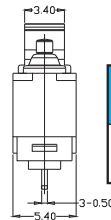
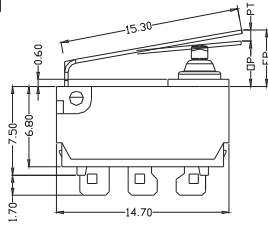

OF Max. (gf)	RF Min. (gf)	PT Max. (mm)	OT Min. (mm)	DT Max. (mm)	FP Max. (mm)	OP (mm)
-130	195	25	3.5	1.35	0.6	6.8
						3.7±0.6

## ◆ G3□□-□□□S05A1

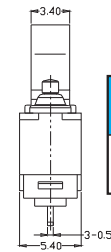
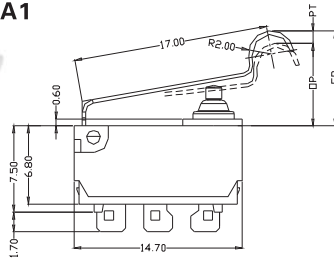

OF Max. (gf)	RF Min. (gf)	PT Max. (mm)	OT Min. (mm)	DT Max. (mm)	FP Max. (mm)	OP (mm)
-130	180	20	3.8	1.5	0.7	9.8
						7.0±0.7

## ◆ G3□□-□□□S00A3

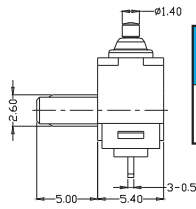
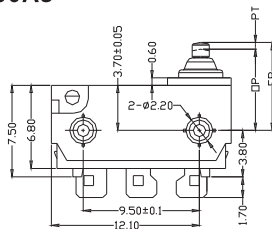

OF Max. (gf)	RF Min. (gf)	PT Max. (mm)	OT Min. (mm)	DT Max. (mm)	FP Max. (mm)	OP (mm)
130	130	13	0.8	0.8	0.2	7.35
						6.75±0.2

## ◆ G3□□-□□□S01A3

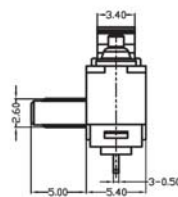
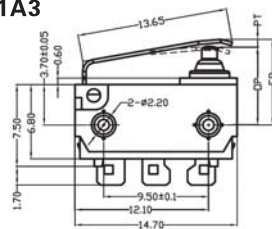

OF Max. (gf)	RF Min. (gf)	PT Max. (mm)	OT Min. (mm)	DT Max. (mm)	FP Max. (mm)	OP (mm)
-130	220	30	3	0.8	0.5	9.4
						7.1±0.5

## ◆ G3□□-□□□S02A3

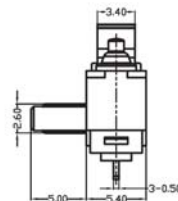
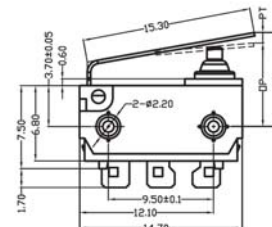

OF Max. (gf)	RF Min. (gf)	PT Max. (mm)	OT Min. (mm)	DT Max. (mm)	FP Max. (mm)	OP (mm)
-130	195	25	3.5	1.35	0.6	10.5
						7.4±0.6

## ■ 外形尺寸和操作特性 Dimensions and Operating Characteristics

### ◆ G3□□-□□□S05A3

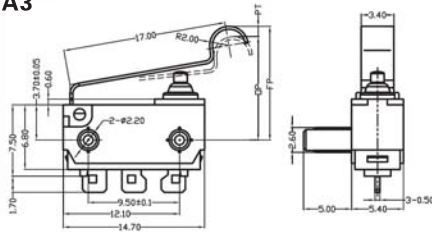

OF Max. (gf)	RF Min. (gf)	PT Max. (mm)	OT Min. (mm)	DT Max. (mm)	FP Max. (mm)	OP (mm)
-130	180	20	3.8	1.5	0.7	13.5
						10.7±0.7

### ◆ G3□□-□□□S09A3

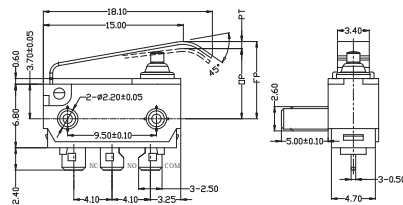

OF Max. (gf)	RF Min. (gf)	PT Max. (mm)	OT Min. (mm)	DT Max. (mm)	FP Max. (mm)	OP (mm)
-130	195	30	3.5	1.3	0.6	10.8
						7.3±0.6

### ◆ G3□□-□□□P15A3

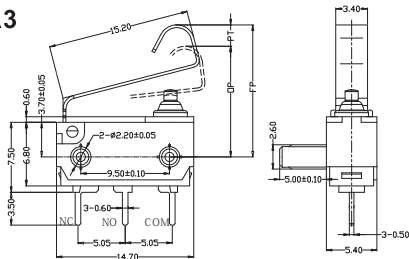

OF Max. (gf)	RF Min. (gf)	PT Max. (mm)	OT Min. (mm)	DT Max. (mm)	FP Max. (mm)	OP (mm)
-130	280	30	4	1.5	0.7	15.9
						11.90±0.7

### ◆ G3□□-□□□P22A3

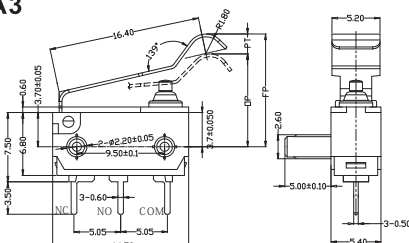

OF Max. (gf)	RF Min. (gf)	PT Max. (mm)	OT Min. (mm)	DT Max. (mm)	FP Max. (mm)	OP (mm)
-130	200	20	3.8	1.5	0.7	13.8
						10.0±0.7

### ◆ G3□□-□□□S25A3

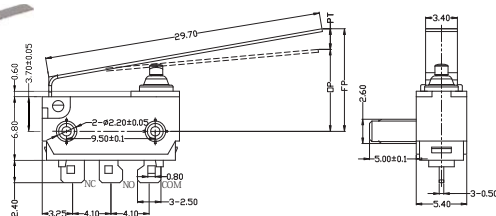

OF Max. (gf)	RF Min. (gf)	PT Max. (mm)	OT Min. (mm)	DT Max. (mm)	FP Max. (mm)	OP (mm)
-130	150	25	5.5	1.35	1.5	13
						7.50±1.2

## ■ 外形尺寸和操作特性 Dimensions and Operating Characteristics

### ◆ G3□□-□□□S28A3

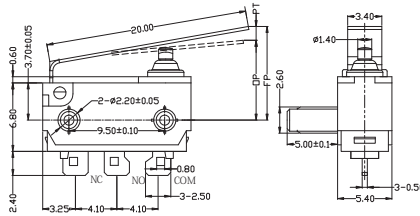

OF Max. (gf)	RF Min. (gf)	PT Max. (mm)	OT Min. (mm)	DT Max. (mm)	FP Max. (mm)	OP (mm)	
-130	200	25	4.5	1.5	1	11.65	7.15±1.0

### ◆ G3□□-□□□S35A3

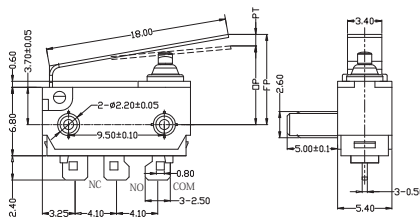

OF Max. (gf)	RF Min. (gf)	PT Max. (mm)	OT Min. (mm)	DT Max. (mm)	FP Max. (mm)	OP (mm)	
-130	200	25	4.4	1.5	1	11.45	7.05±1.0

### ◆ G3□□-□□□S36A3

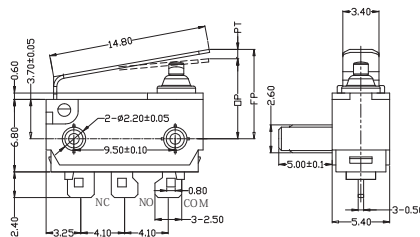

OF Max. (gf)	RF Min. (gf)	PT Max. (mm)	OT Min. (mm)	DT Max. (mm)	FP Max. (mm)	OP (mm)	
-130	200	25	3.4	1.3	0.6	10.6	7.2±0.6

### ◆ G3□□-□□□P41A3

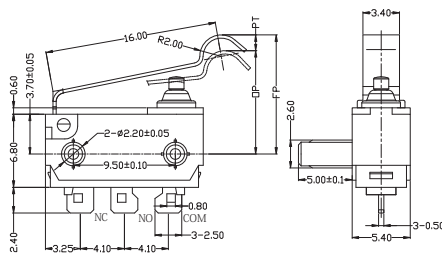

OF Max. (gf)	RF Min. (gf)	PT Max. (mm)	OT Min. (mm)	DT Max. (mm)	FP Max. (mm)	OP (mm)	
-130	200	50	3.5	1.2	0.6	13	9.5±0.7

## ■ 外形尺寸和操作特性 Dimensions and Operating Characteristics

### ◆ G3□□-□□□K00A4

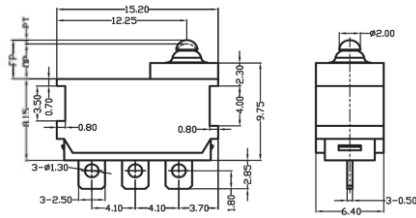

OF Max. (gf)	RF Min. (gf)	PT Max. (mm)	OT Min. (mm)	DT Max. (mm)	FP Max. (mm)	OP (mm)
-130	130	13	0.8	0.8	0.2	4.1
						3.45±0.2

### ◆ G3□□-□□□K00A6

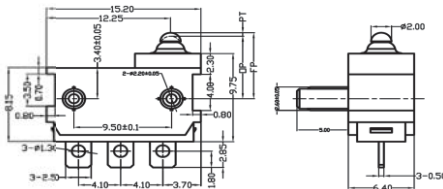

OF Max. (gf)	RF Min. (gf)	PT Max. (mm)	OT Min. (mm)	DT Max. (mm)	FP Max. (mm)	OP (mm)
-130	130	13	0.8	0.8	0.2	7.5
						6.85±0.2

### ◆ G3□□-□□□K00A7

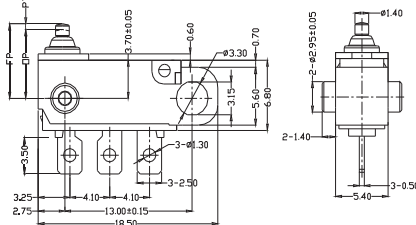

OF Max. (gf)	RF Min. (gf)	PT Max. (mm)	OT Min. (mm)	DT Max. (mm)	FP Max. (mm)	OP (mm)
-130	130	13	0.8	0.8	0.2	7.35
						6.75±0.2

### ◆ G3□□-□□□K05A7

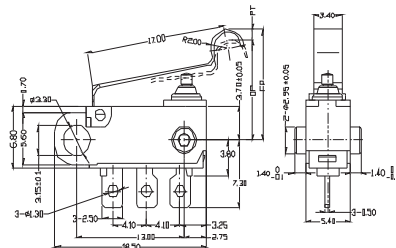

OF Max. (gf)	RF Min. (gf)	PT Max. (mm)	OT Min. (mm)	DT Max. (mm)	FP Max. (mm)	OP (mm)
-130	180	20	3.8	1.5	0.7	13.5
						10.7±0.7

### ◆ G3□□-□□□K01A2

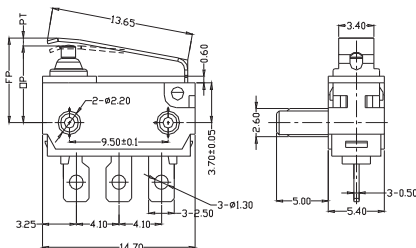

OF Max. (gf)	RF Min. (gf)	PT Max. (mm)	OT Min. (mm)	DT Max. (mm)	FP Max. (mm)	OP (mm)
-130	220	30	2	0.8	0.5	9.4
						7.1±0.5

## ■ 外形尺寸和操作特性 Dimensions and Operating Characteristics

### ◆ G3□□-□□□P00A3

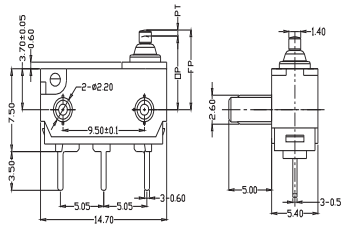

OF Max. (gf)	RF Min. (gf)	PT Max. (mm)	OT Min. (mm)	DT Max. (mm)	FP Max. (mm)	OP (mm)
-130	130	13	0.8	0.8	0.2	7.35
6.75±0.2						

### ◆ G3□□-□□□E00A3-□□

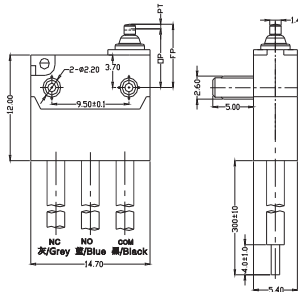

OF Max. (gf)	RF Min. (gf)	PT Max. (mm)	OT Min. (mm)	DT Max. (mm)	FP Max. (mm)	OP (mm)
-130	130	13	0.8	0.8	0.2	7.35
6.75±0.2						

### ◆ G3□□-□□□E10C3

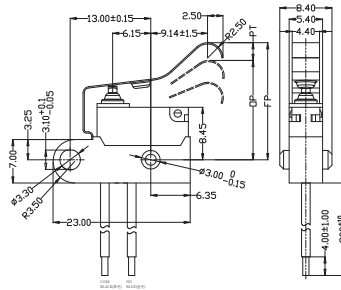

OF Max. (gf)	RF Min. (gf)	PT Max. (mm)	OT Min. (mm)	DT Max. (mm)	FP Max. (mm)	OP (mm)
-130	100	25	6	1.5	2	21
15±2.0						

### ◆ G3□□-□□□E00A7-□□

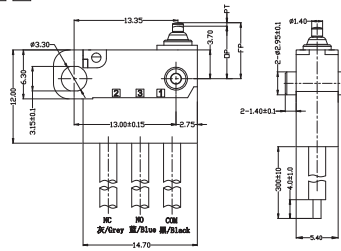

OF Max. (gf)	RF Min. (gf)	PT Max. (mm)	OT Min. (mm)	DT Max. (mm)	FP Max. (mm)	OP (mm)
-130	130	13	0.8	0.8	0.2	7.35
6.75±0.2						

### ◆ G3□□-□□□E05A7-□□

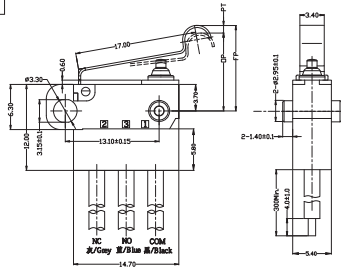

OF Max. (gf)	RF Min. (gf)	PT Max. (mm)	OT Min. (mm)	DT Max. (mm)	FP Max. (mm)	OP (mm)
-130	180	20	3.8	1.5	0.7	13.5
10.7±0.7						

## ■ 外形尺寸和操作特性 Dimensions and Operating Characteristics

### ◆ G3□□-□□□G00A3-□□

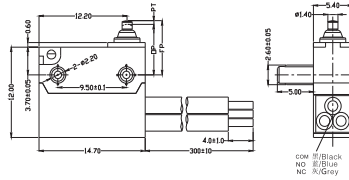

OF Max. (gf)	RF Min. (gf)	PT Max. (mm)	OT Min. (mm)	DT Max. (mm)	FP Max. (mm)	OP (mm)
-130	130	13	0.8	0.8	0.2	7.35
6.75±0.2						

### ◆ G3□□-□□□S00A13

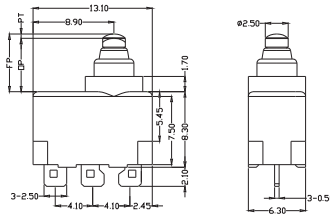

OF Max. (gf)	RF Min. (gf)	PT Max. (mm)	OT Min. (mm)	DT Max. (mm)	FP Max. (mm)	OP (mm)
-130	180	20	1.5	0.5	0.25	6.35
5.4±0.3						

### ◆ G3□□-□□□S00A15

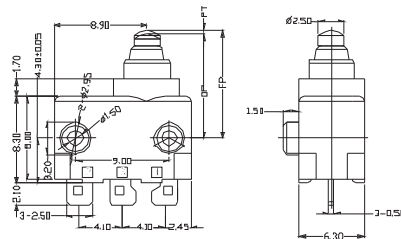

OF Max. (gf)	RF Min. (gf)	PT Max. (mm)	OT Min. (mm)	DT Max. (mm)	FP Max. (mm)	OP (mm)
-130	180	20	1.5	0.5	0.25	10.35
9.4±0.3						

### ◆ G3□□-□□□S03A12

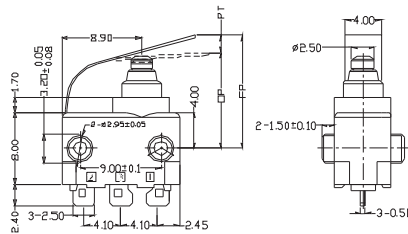

OF Max. (gf)	RF Min. (gf)	PT Max. (mm)	OT Min. (mm)	DT Max. (mm)	FP Max. (mm)	OP (mm)
-130	250	50	5.5	0.5	1.1	15
10.7±1.5						

### ◆ G3□□-□□□S00A16

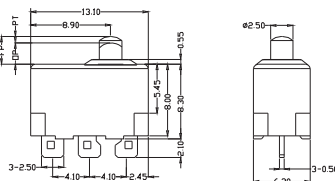

OF Max. (gf)	RF Min. (gf)	PT Max. (mm)	OT Min. (mm)	DT Max. (mm)	FP Max. (mm)	OP (mm)
-130	130	8	1.5	0.5	0.25	3.3
2.2±0.3						

### ◆ G3□□-□□□S00A18

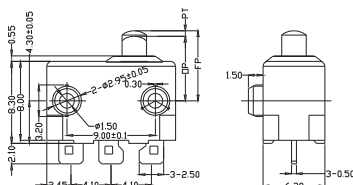

OF Max. (gf)	RF Min. (gf)	PT Max. (mm)	OT Min. (mm)	DT Max. (mm)	FP Max. (mm)	OP (mm)
-130	130	8	1.5	0.5	0.25	7.3
6.2±0.3						



## ■ 外形尺寸和操作特性 Dimensions and Operating Characteristics

### ◆ G3□□-□□□E00A47-□□

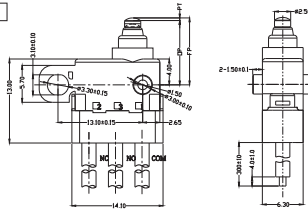

OF Max. (gf)	RF Min. (gf)	PT Max. (mm)	OT Min. (mm)	DT Max. (mm)	FP Max. (mm)	OP (mm)	
-130	200	20	1.5	0.5	0.25	0.35	9.4±0.3

### ◆ G3□□-□□□E23A47-□□

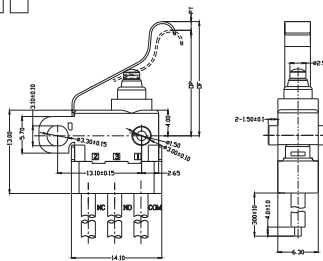

OF Max. (gf)	RF Min. (gf)	PT Max. (mm)	OT Min. (mm)	DT Max. (mm)	FP Max. (mm)	OP (mm)	
-130	300	50	3.5	0.5	1.1	20	16.45±1.5

### ◆ G3□□-□□□P00A52

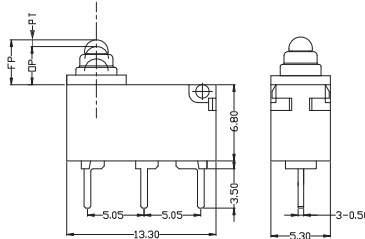

OF Max. (gf)	RF Min. (gf)	PT Max. (mm)	OT Min. (mm)	DT Max. (mm)	FP Max. (mm)	OP (mm)	
-130	130	30	1.3	0.6	0.25	4.2	3.4±0.5

### ◆ G3□□-□□□P00A53

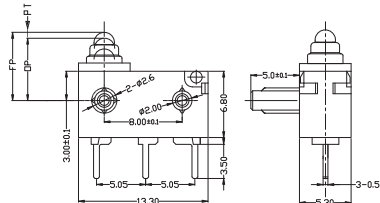

OF Max. (gf)	RF Min. (gf)	PT Max. (mm)	OT Min. (mm)	DT Max. (mm)	FP Max. (mm)	OP (mm)	
-130	130	30	1.3	0.6	0.25	7.2	6.4±0.5

### ◆ G3□□-□□□E00A48-□□

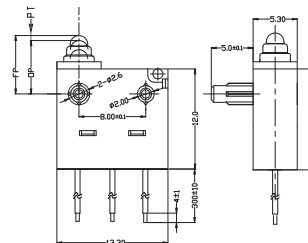

OF Max. (gf)	RF Min. (gf)	PT Max. (mm)	OT Min. (mm)	DT Max. (mm)	FP Max. (mm)	OP (mm)	
-130	130	30	1.3	0.6	0.25	7.2	6.4±0.5

### ◆ G3□□-□□□E00A49-□□

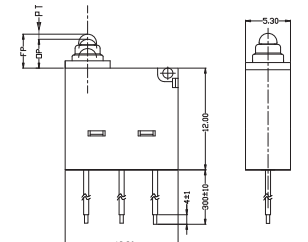

OF Max. (gf)	RF Min. (gf)	PT Max. (mm)	OT Min. (mm)	DT Max. (mm)	FP Max. (mm)	OP (mm)	
-130	130	30	1.3	0.6	0.25	4.2	3.4±0.5